

Modeling the Effects Introduced by the Real Structure of a Diffractive Lens in a Hybrid Eyepiece

Abstract

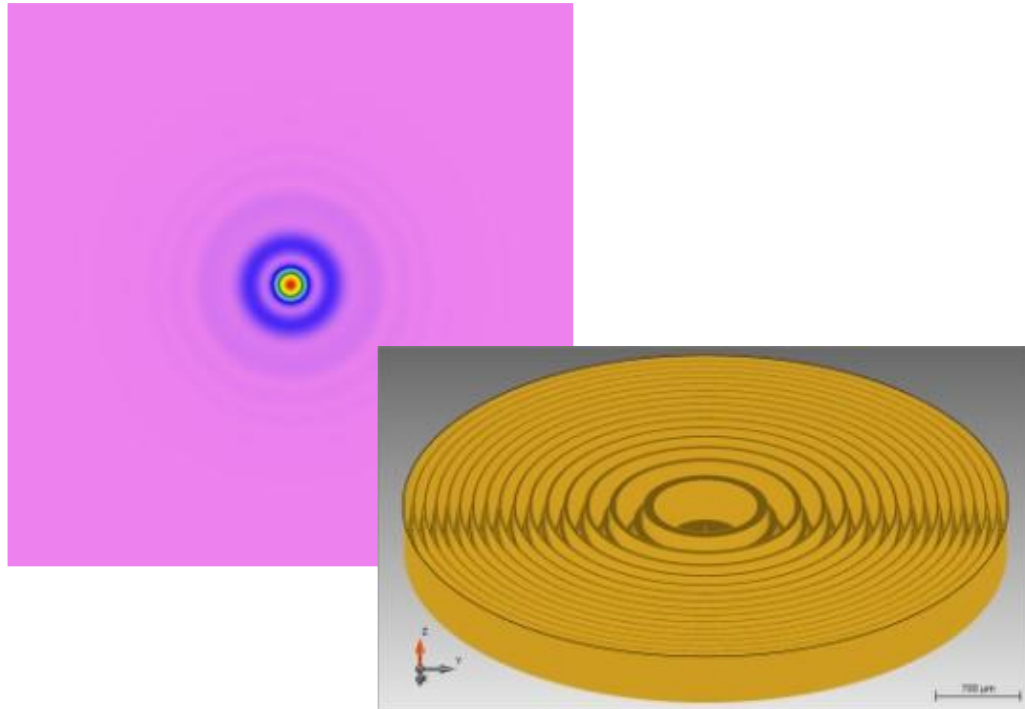

Hybrid lenses with both refractive and diffractive surfaces have become a promising solution for different applications. Here we demonstrate an example of a hybrid eyepiece, in which a diffractive lens modeled as a real surface is used to correct chromatic aberration. Propagation through the diffractive grating structure is handled with the Local Linear Grating Approximation (LLGA) electromagnetic field solver, with a combination of the Thin Element Approximation (TEA) and the Fourier Modal Method (FMM) as the base local solvers. An internal accuracy criterion controls which of the two algorithms is used at which lateral position.

Design and Modeling Task

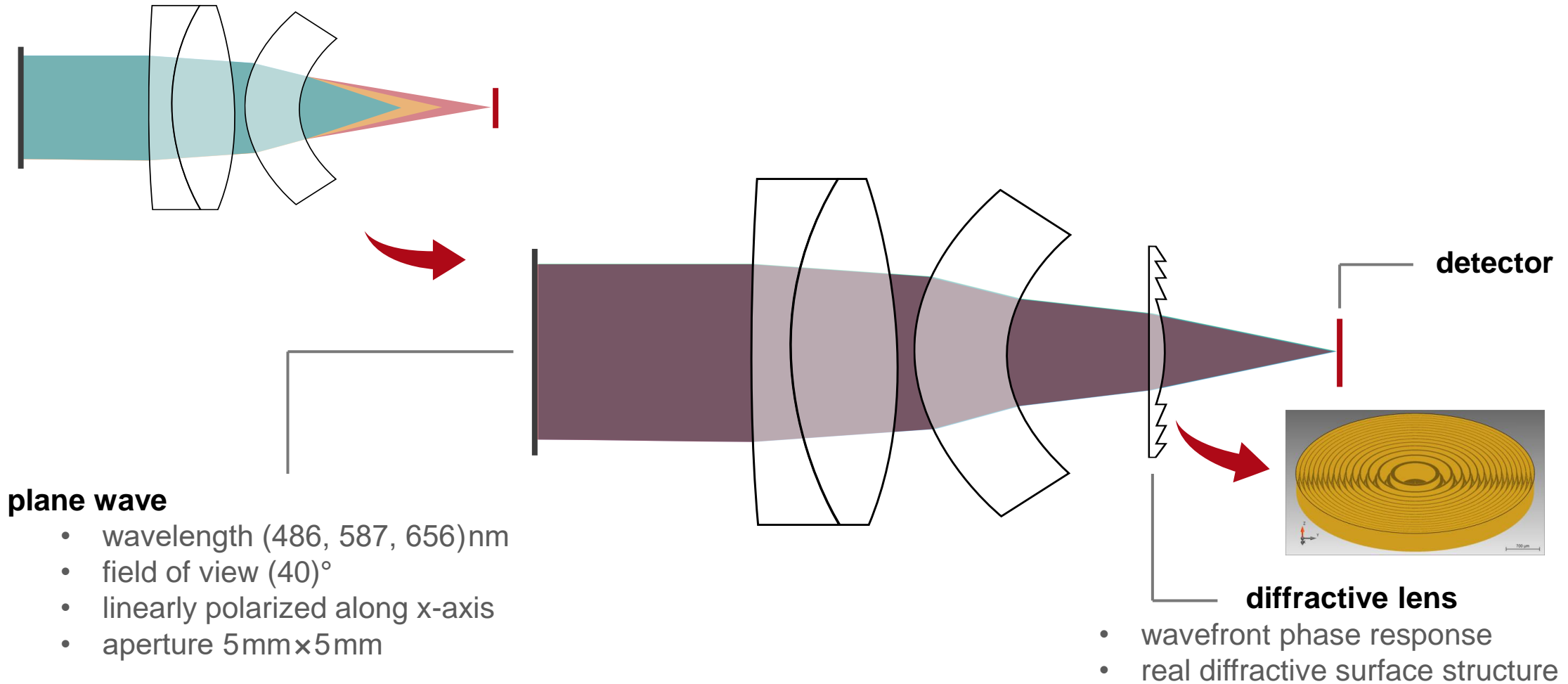

Imported Lens File

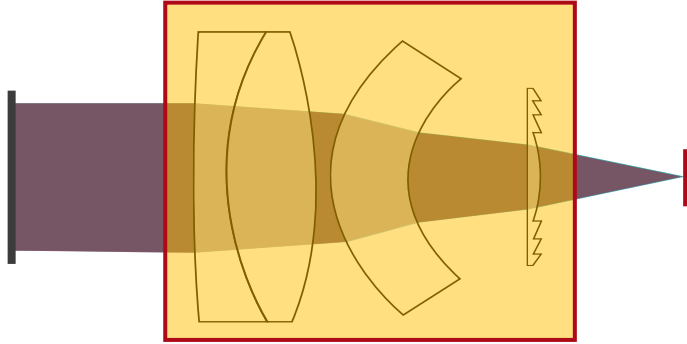

The initial design is taken from Zemax OpticStudio® and imported into VirtualLab Fusion.

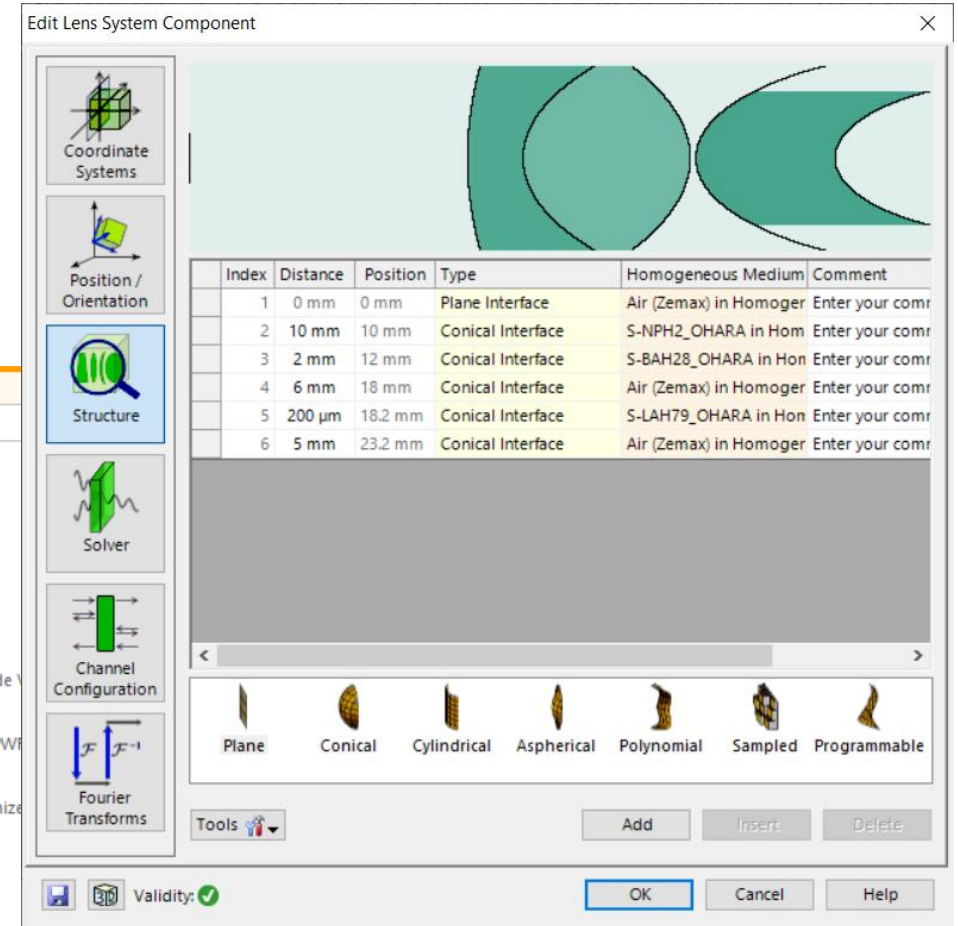
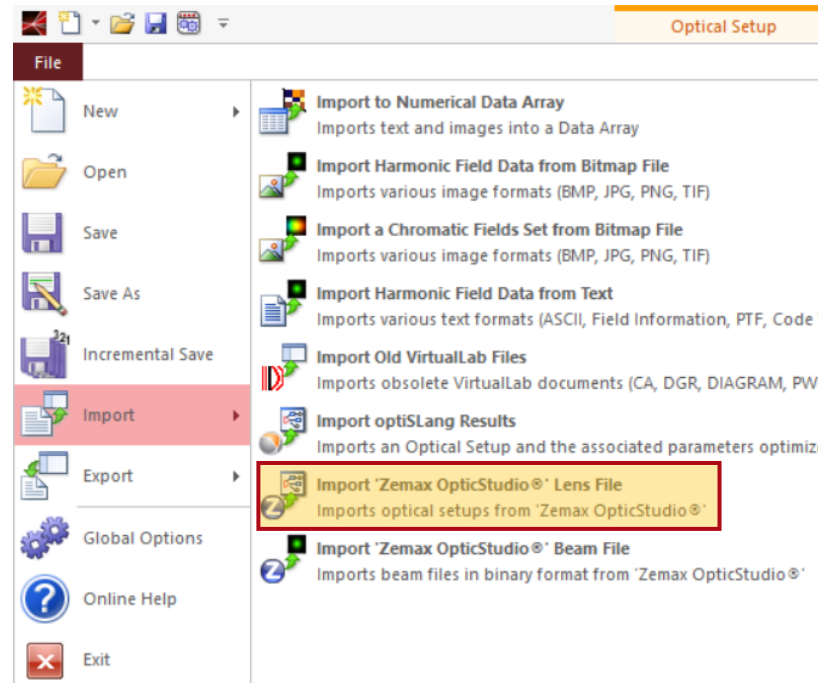

Configuration of Parameters of Real Diffractive Lens

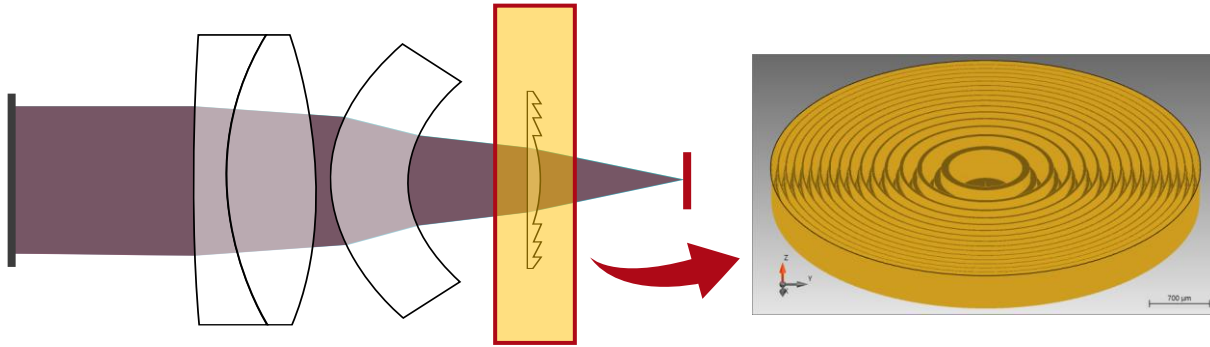

- The *Wavefront Phase Response* introduced by the diffractive lens is defined in the *Channel Operator* tab.
- The structure of the real diffractive lens that corresponds to the desired *Wavefront Phase Response* is calculated internally by the component, and can be further adapted through the design wavelength, the height scaling, and the quantization level. In addition, the user can choose which diffractive orders are used for simulation.
- The propagation through the real diffractive lens is then modeled by the Local Linear Grating Approximation (LLGA). For further information, please see [Diffractive Lens Component](#)

Edit Diffractive Lens Component

Solid Channel Operator Diffractive Structure Model

Wavefront Phase Response

Degree of Polynomial 6

Exponent	Coefficient
2	-1051 rad
4	1133.1 rad
6	-878.29 rad

Normalization Radius 7.7525 mm

Edit Diffractive Lens Component

Solid Channel Operator Diffractive Structure Model

Idealized Grating Structure Real Structure

Design Wavelength 587.72 nm

Height Scaling Factor 1

Use Profile Quantization

Number of Height Levels 2

Export Structure

Orders for Simulation

Order
-1
0
+1

Add Order Remove Order

Solver

Summary – Components...

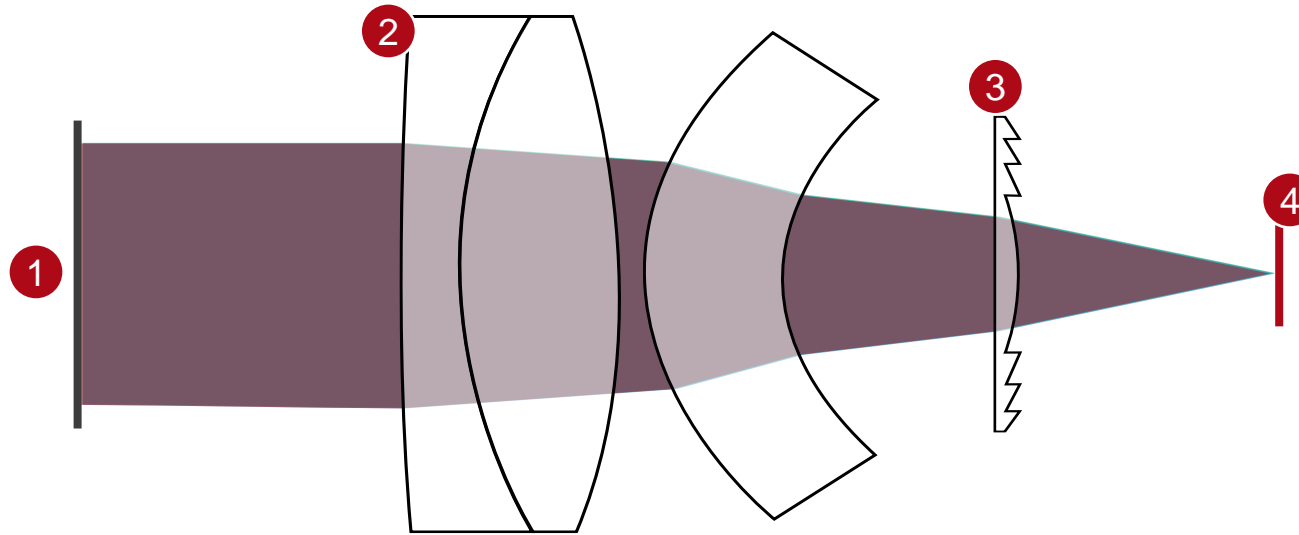

... of Optical System	... in VirtualLab Fusion	Model/Solver/Detected Magnitude
1. source	<i>Plane Wave</i>	truncated Ideal Plane Wave
2. eye-piece	<i>Lens System Component</i>	Local Plane Interface Approximation (LPIA)
3. diffractive element	<i>Diffractive Lens Component</i>	LLGA (with Thin Element Approximation / Fourier Modal Method)
4. detector	<i>Camera Detector</i>	energy density measurement

On-Axis Case: Desired and Unwanted Diffraction Orders

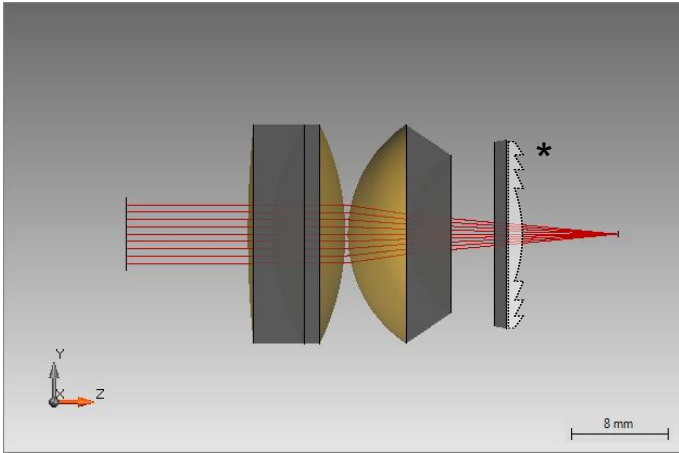

* The real grating profile is added for illustration purposes

For the real diffractive lens, the user can select which diffraction orders are modeled in the simulation. The corresponding intensity distribution will be calculated automatically. Note that the intensity of the working order is much stronger compared to the others.

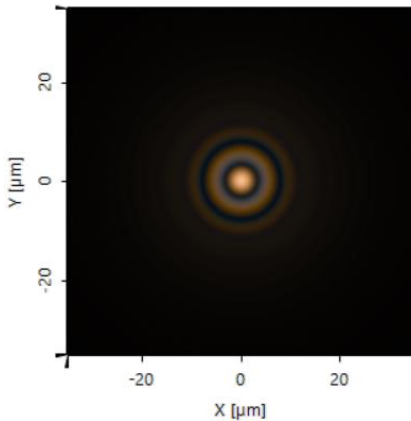
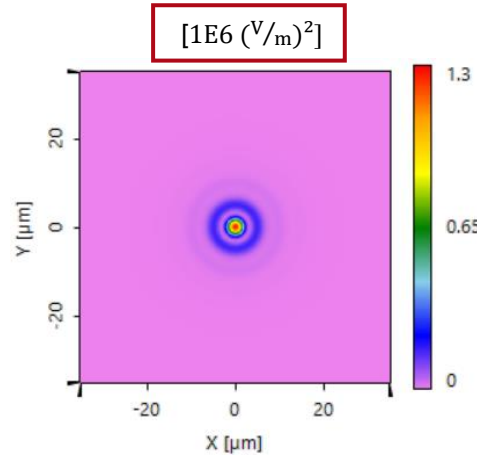

+1st diffraction order
(working order)

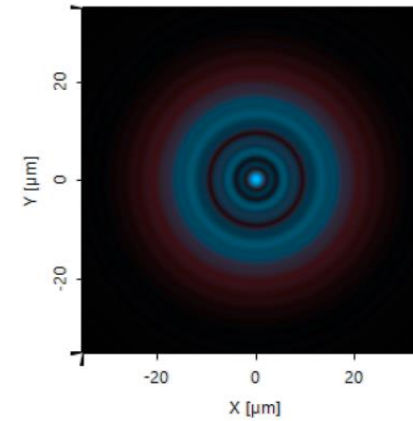
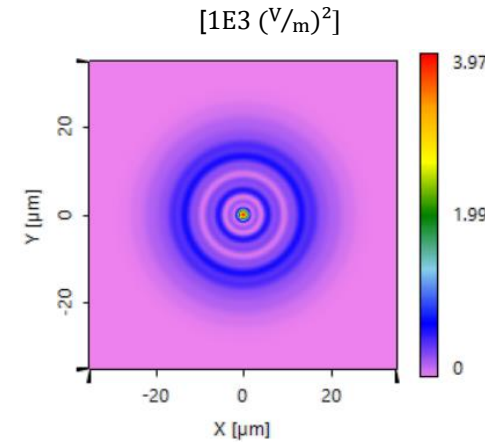

0th diffraction order

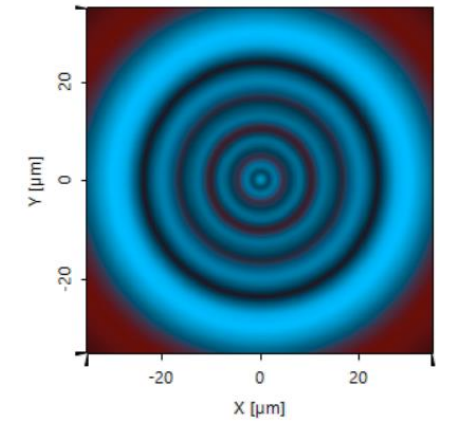
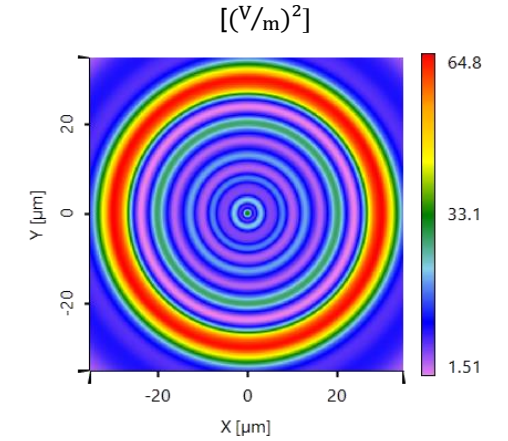

-1st diffraction order

On-Axis Case: Different Quantization Levels

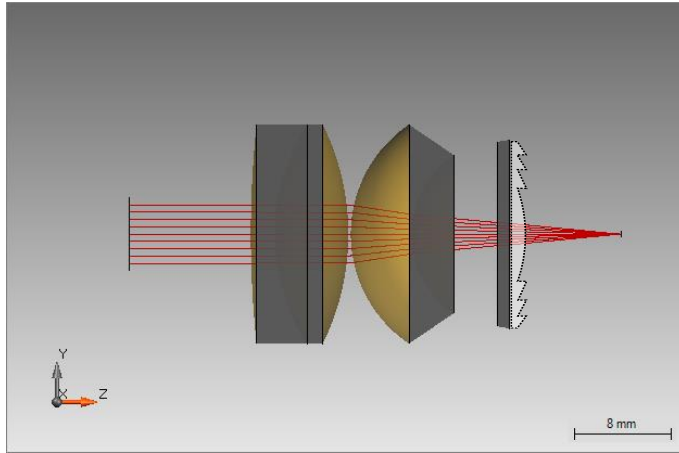

no quantization



[1E6 (V/m)²]

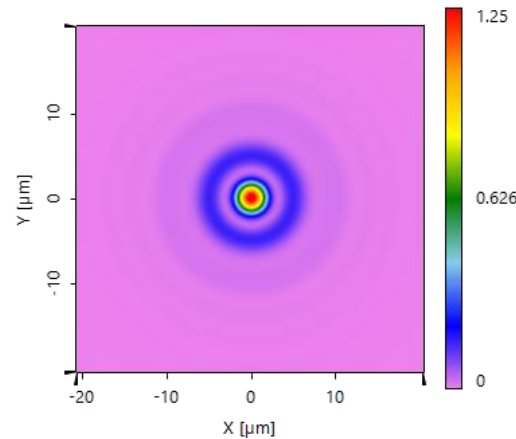

4 levels quantization

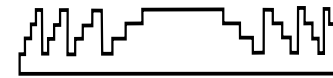

[1E6 (V/m)²]

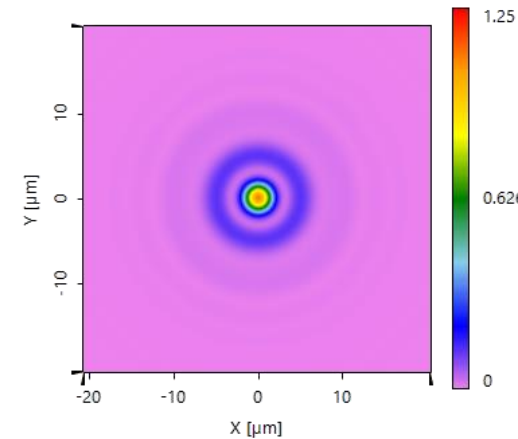

2 levels quantization

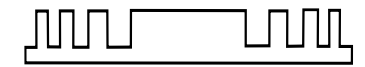

[1E6 (V/m)²]

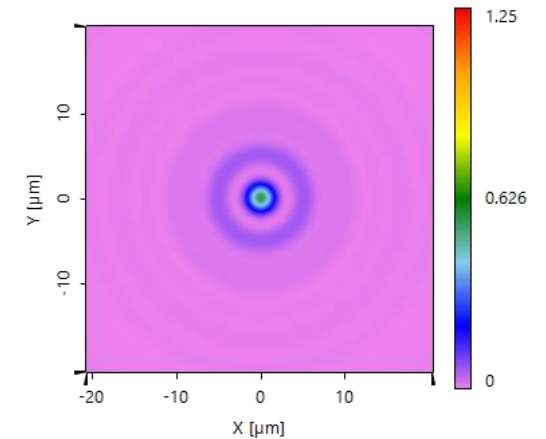

Depending on the fabrication process, the structure may have discrete height levels instead of a smooth surface. This can be modeled by using quantization levels. The field results on this page combine the three configured diffraction orders for each of the quantization scenarios.

On-Axis Case: Height Scaling Factor

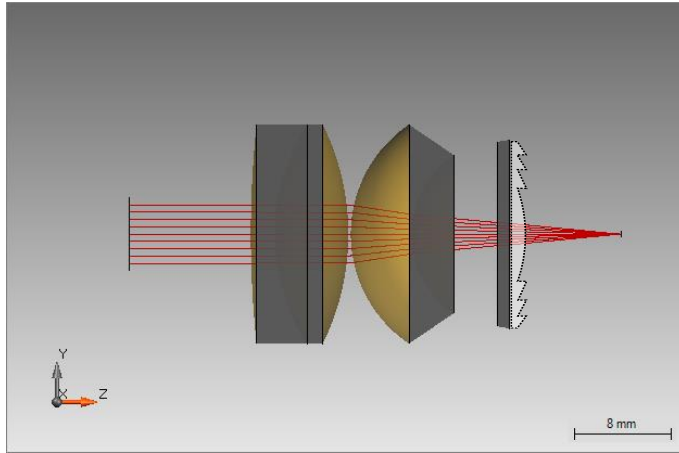

The *Height Scaling Factor* allows for an adjustment of the maximum height of the structure to e.g. investigate tolerance. In this example we show the results for the combination of the three propagating orders considering a 4-level quantization. Please note that the logarithmic color scheme is used in the top row of the results to better display the effect. For a better visualization we only depict the wavelength 588nm here.

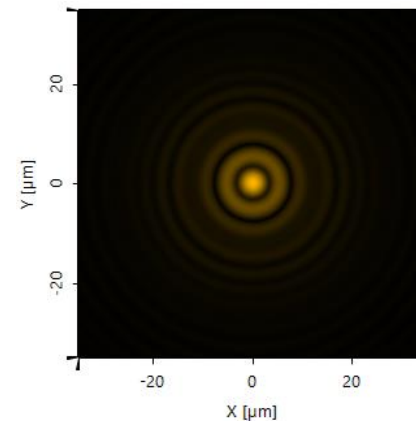
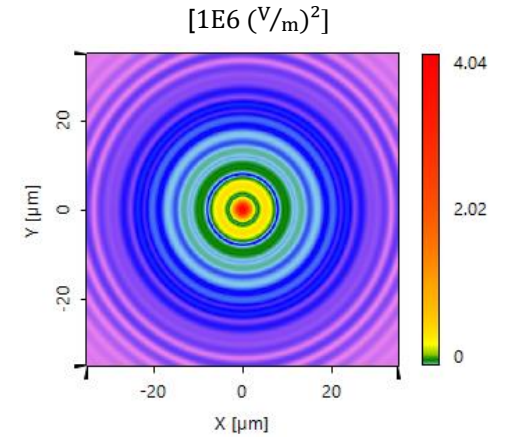
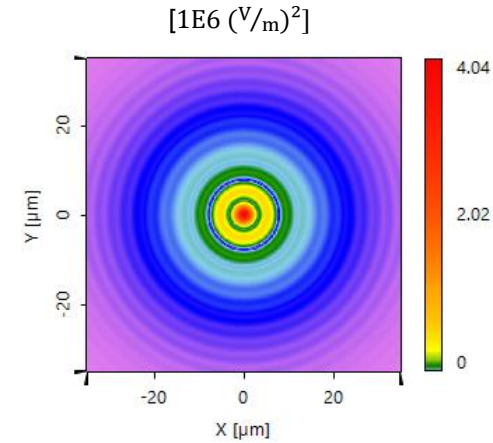
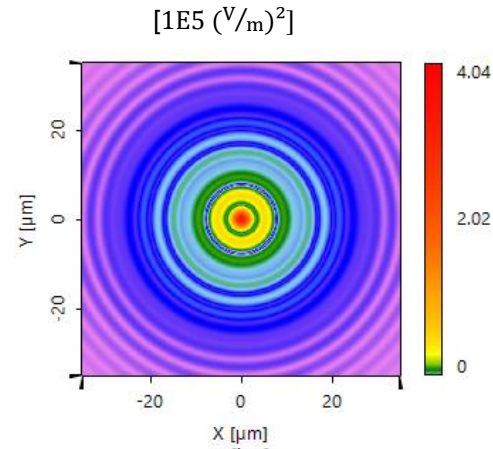

height scaling 0.9

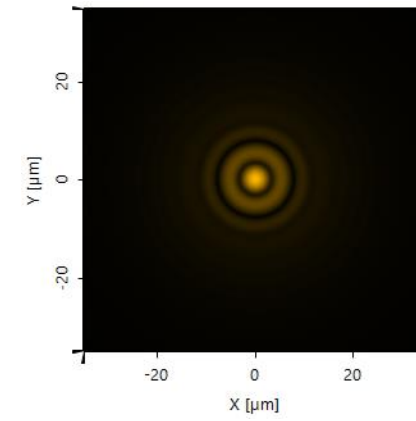

height scaling 1

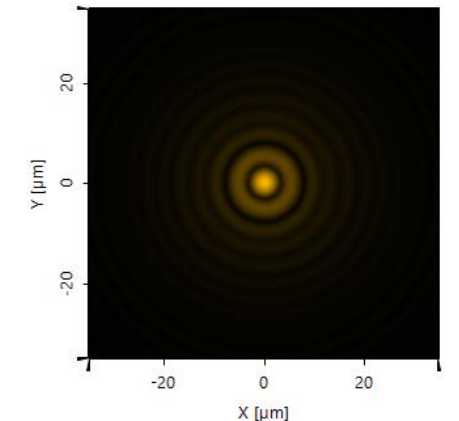

height scaling 1.1

Off-Axis Case: Desired and Unwanted Diffraction Orders

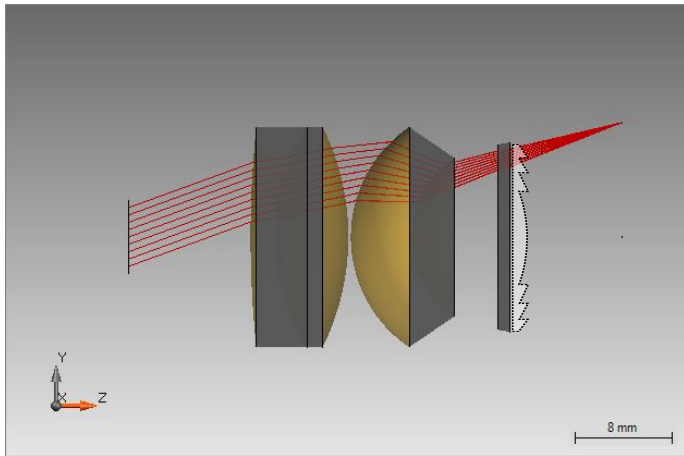

The same investigations can be performed for off-axis incidence.

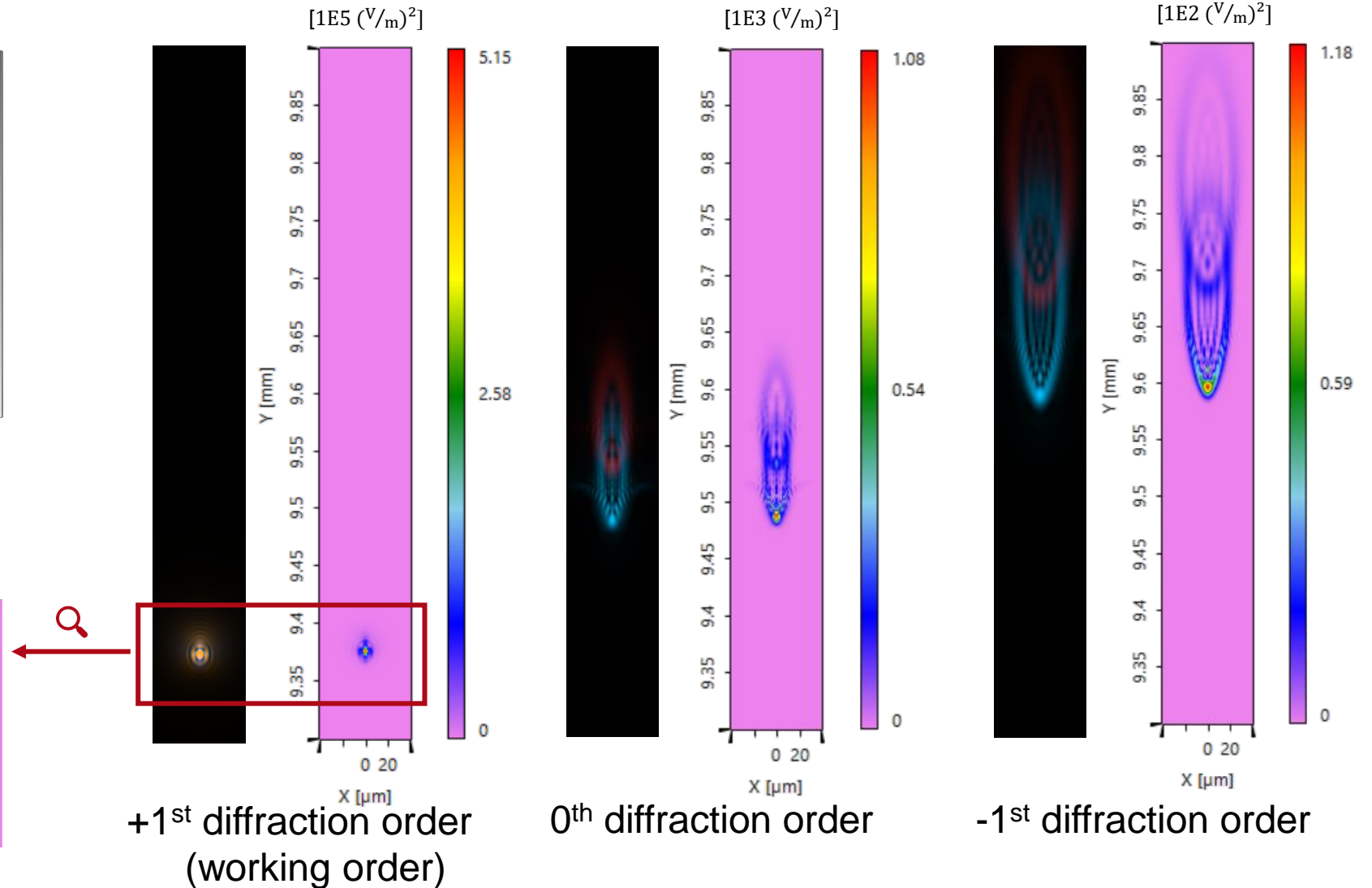
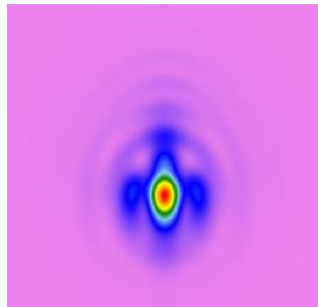
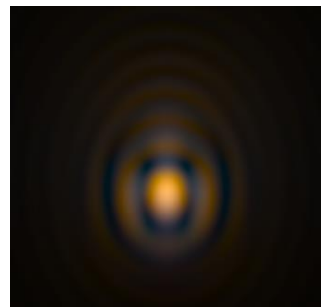

Off-Axis Case: Different Quantization Levels

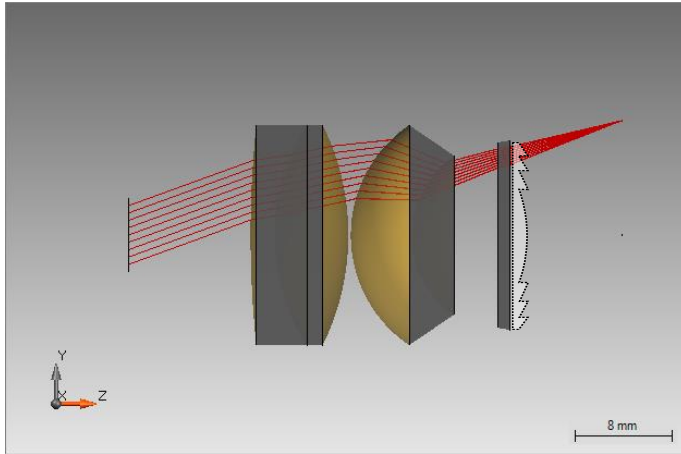

Depending on the fabrication process, the structure may have discrete height levels instead of a smooth surface. This can be modeled using quantization levels. The field results on this page combine the three diffraction orders for each of the quantization scenarios.

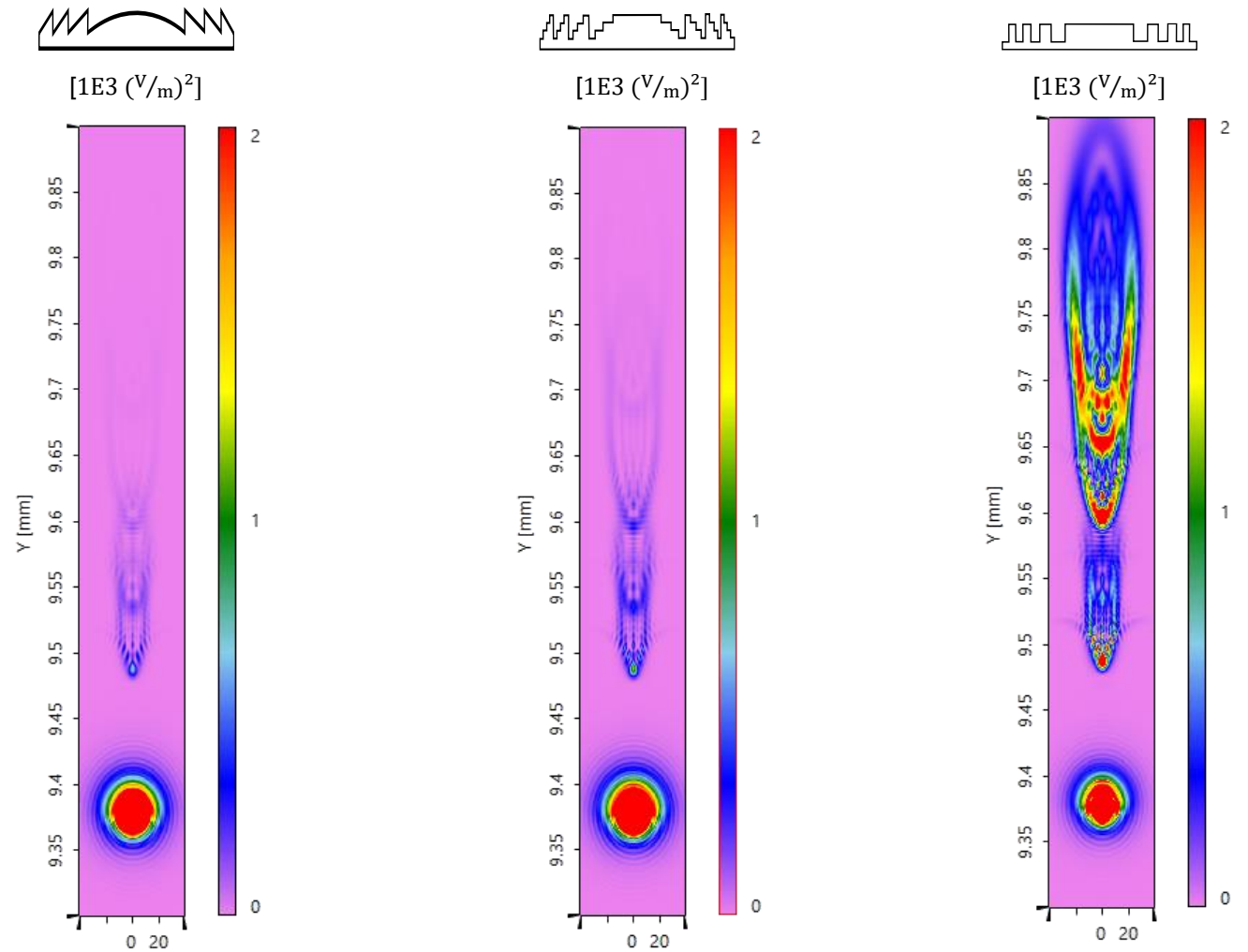

maximum values are clipped for visualization

Off-Axis Case: Height Scaling Factor

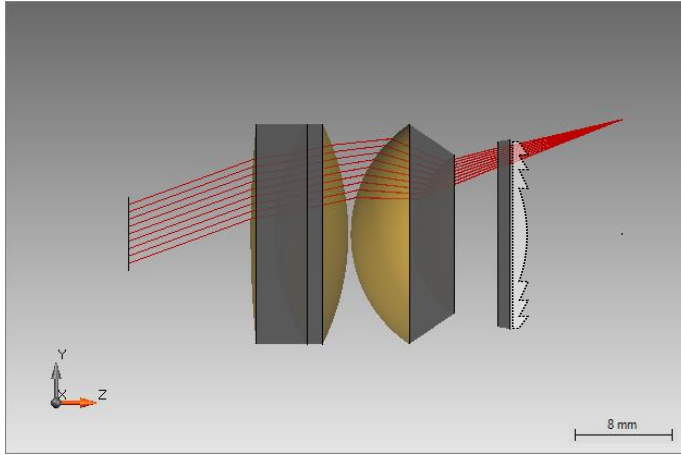

The *Height Scaling Factor* allows for an overall adjustment of the maximum height of the structure to e.g. investigate tolerance. In this example we show the deviations for the combination of the three orders considered using 4-level quantization.

height scaling 0.9

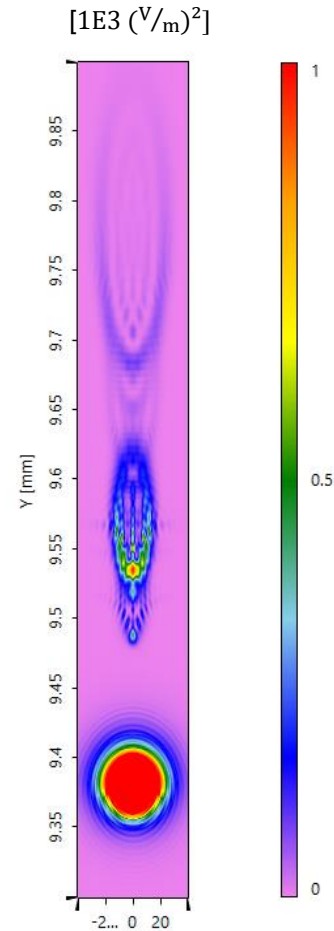

height scaling 1

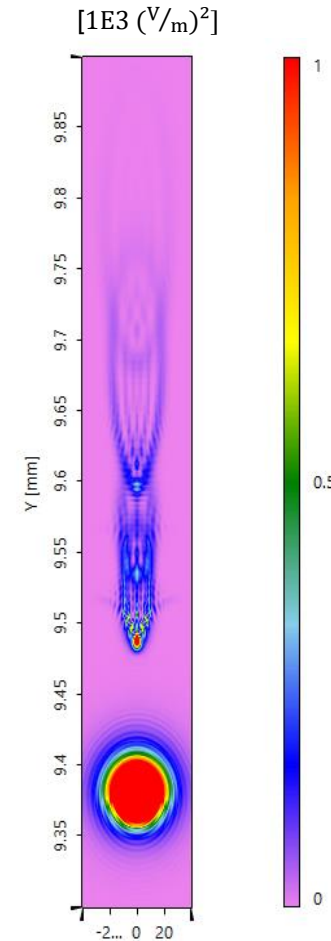

height scaling 1.1

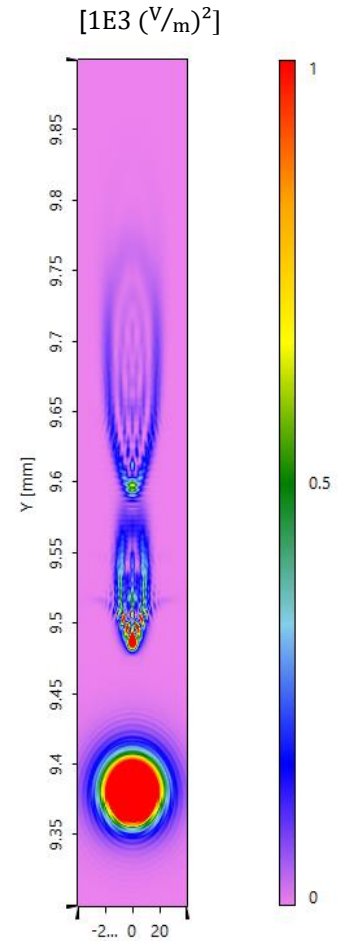

maximum values are clipped for visualization

Comparison between Real and Ideal Diffractive Lens

For an idealized diffractive lens, the efficiency of the working order (+1st diffraction order) is usually defined as 100%. With a real structure, however, some energy is distributed to orders other than the working order (here -1st and 0th order). All three diffraction orders are used for the simulation of the real lens, with no quantization level and height scaling factor 1. Please note that a logarithmic color scheme is used to better display the effect.

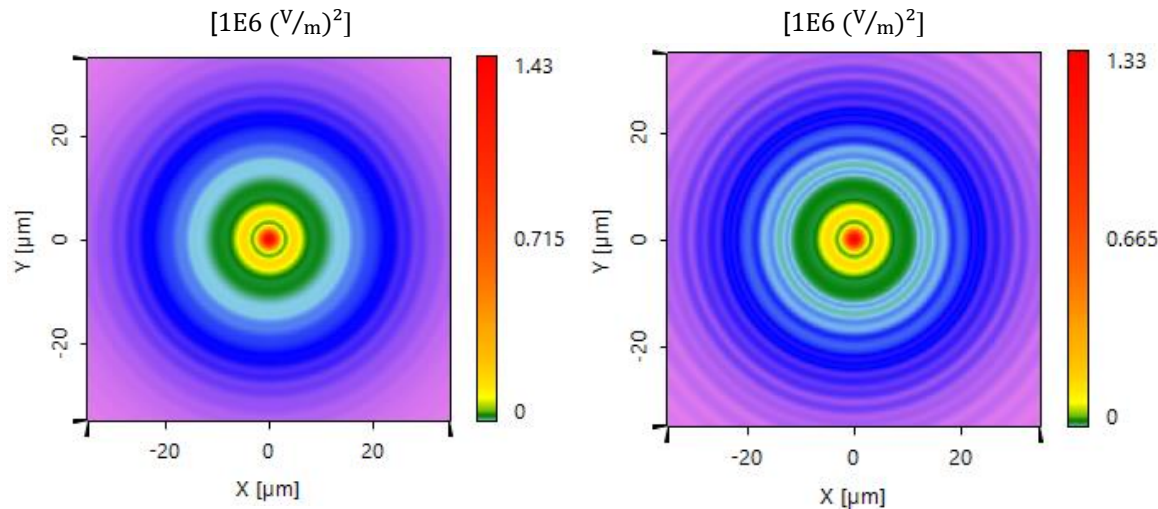

ideal diffractive lens
on axis

real diffractive lens
on axis

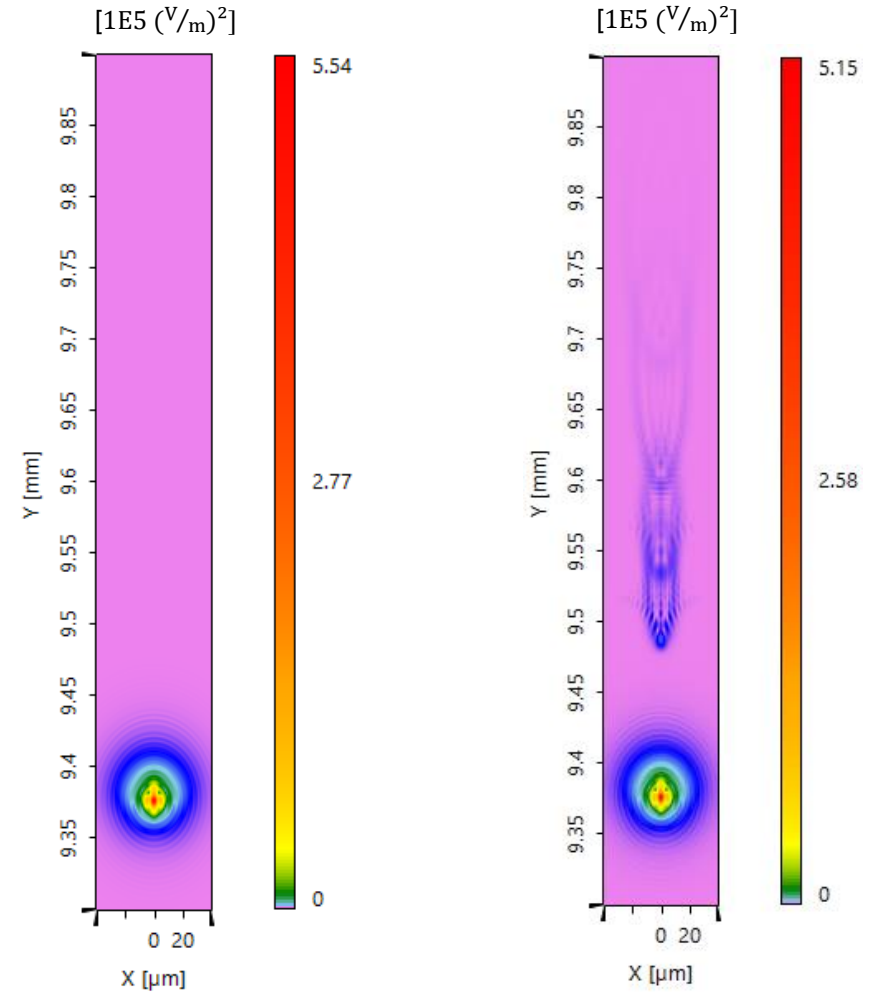

ideal diffractive lens
off axis

real diffractive lens
off axis

VirtualLab Fusion Technologies

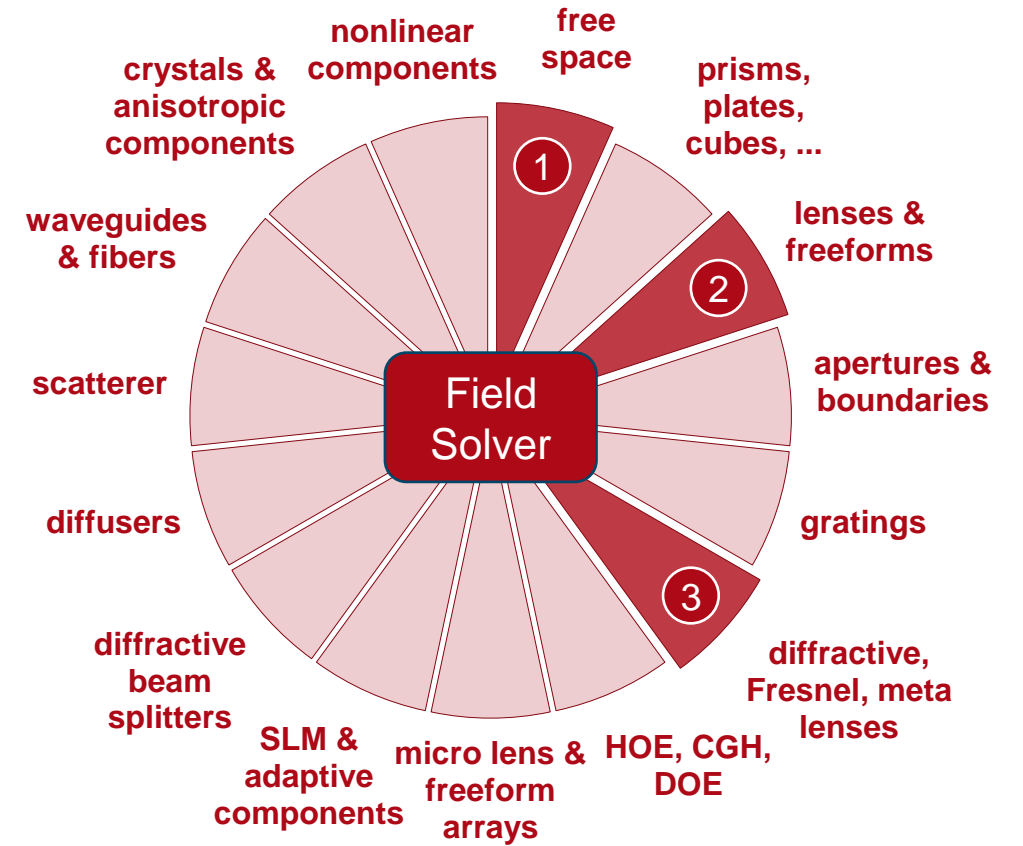
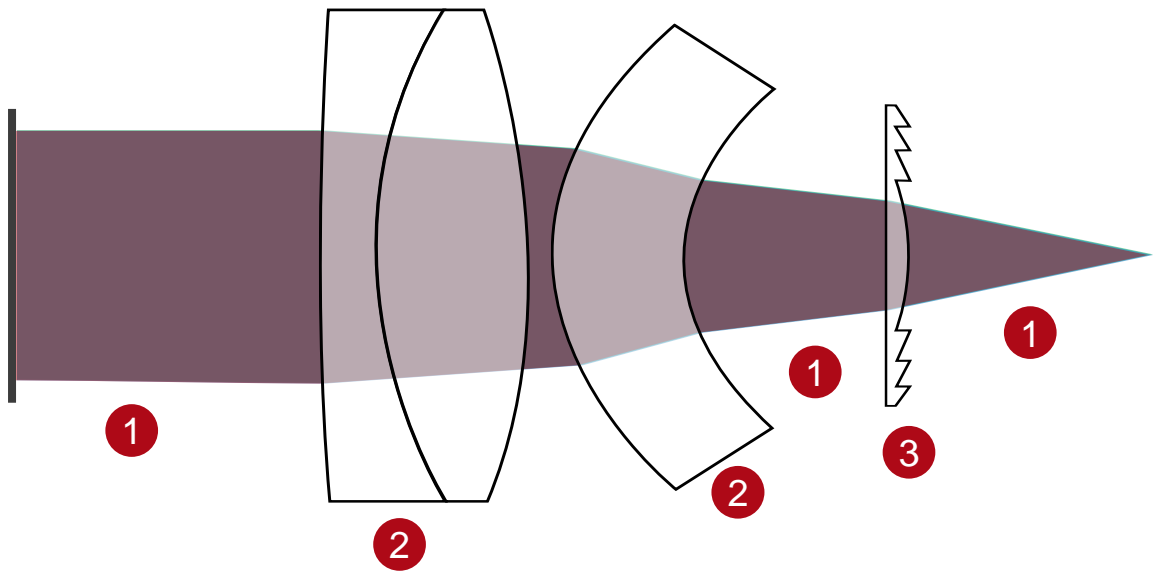

Document Information

title	Modeling the Effects Introduced by the Real Structure of a Diffractive Lens in a Hybrid Eyepiece
document code	DFL.0003
version	1.1
toolbox(es)	<ul style="list-style-type: none">• VirtualLab Fusion Advanced• Diffractive Optics Toolbox Gold
VL version used for simulations	2021.1 (Build 1.180)
category	Application Use Case
further reading	<ul style="list-style-type: none">• Design and Analysis of Intraocular Diffractive Lens• Import Optical Systems from Zemax OpticStudio®