

Gratings in Complex Optical Systems

Abstract

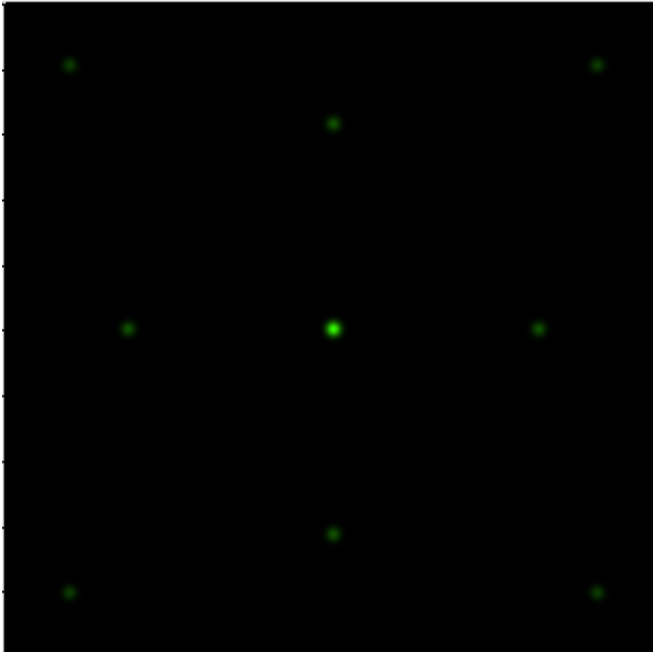

VirtualLab Fusion is capable of simulating light propagation of any kind of light source through a periodic microstructure. The microstructures are analyzed rigorously in order to calculate accurate diffraction efficiencies for structure sizes in the range of the used wavelength. For larger structures, thin element approximation can be applied in order to reduce the numerical effort.

Modeling Task

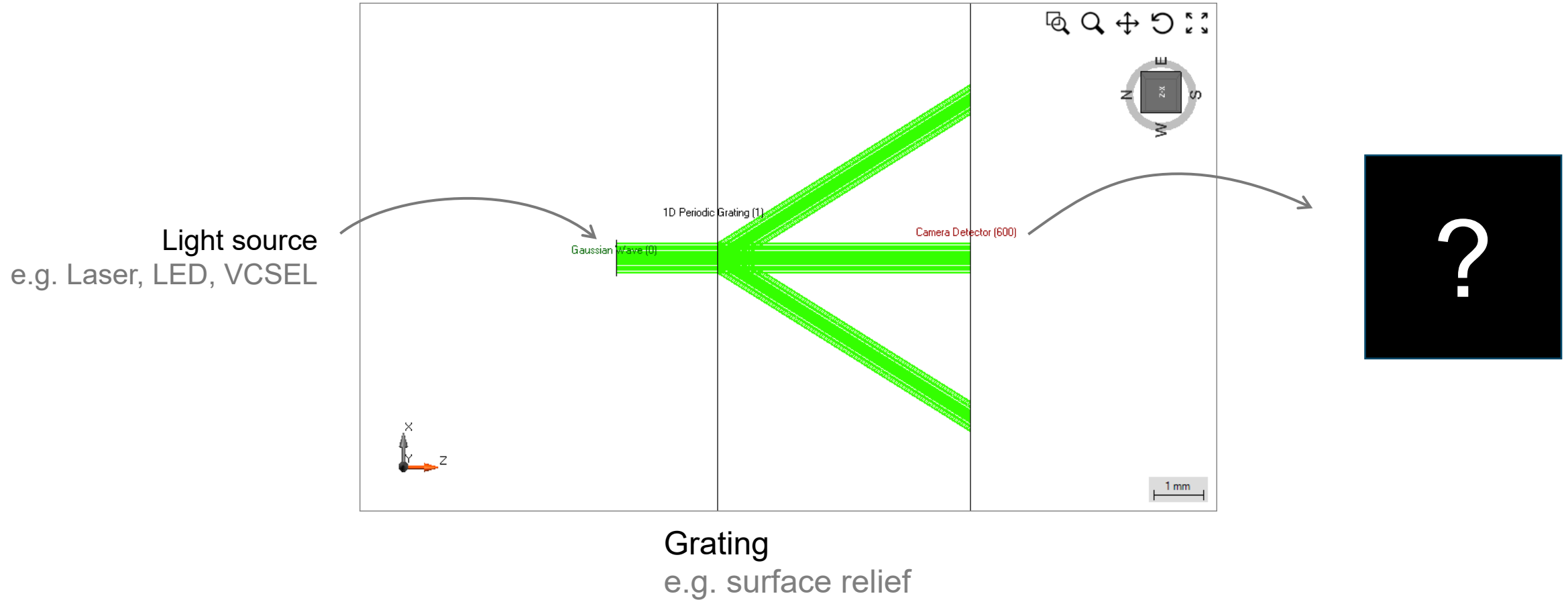

1D – Periodic Grating Structures

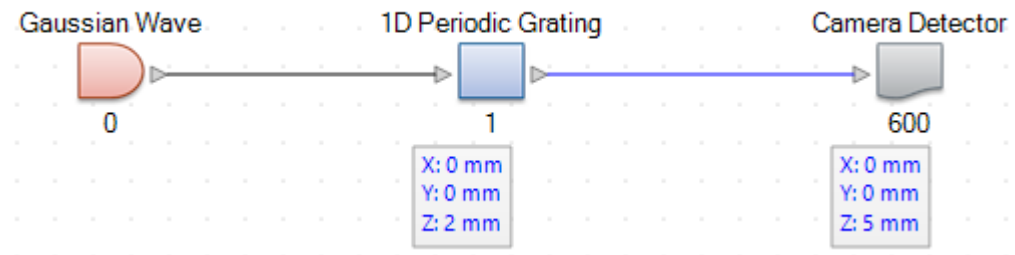

ray tracing:

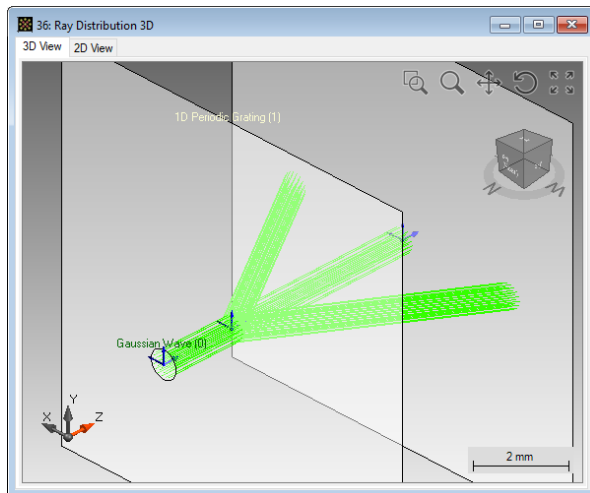

field tracing:

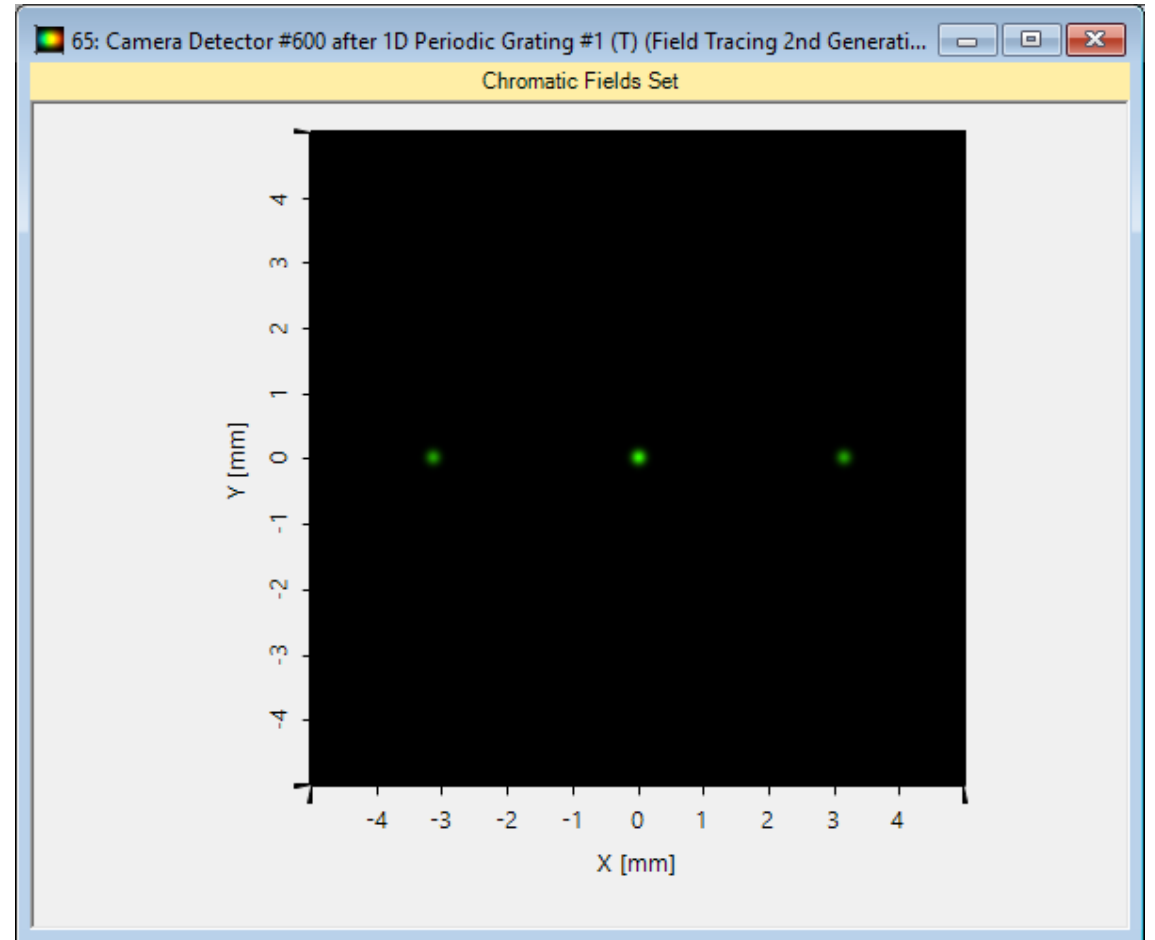

1D – Periodic Grating Structures

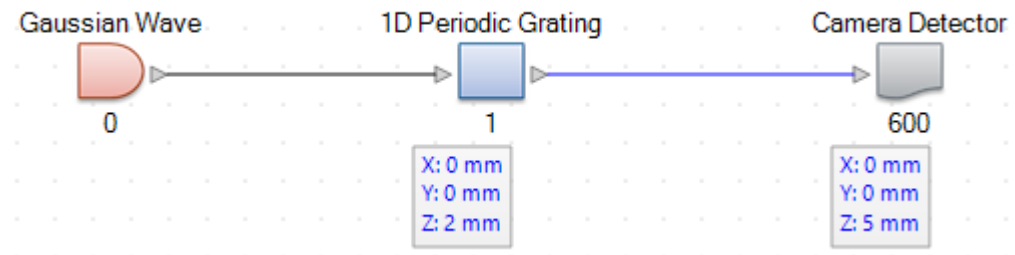

ray tracing:

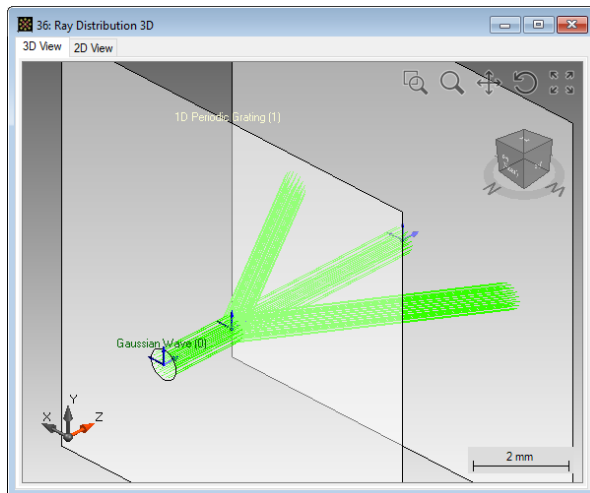

field tracing:

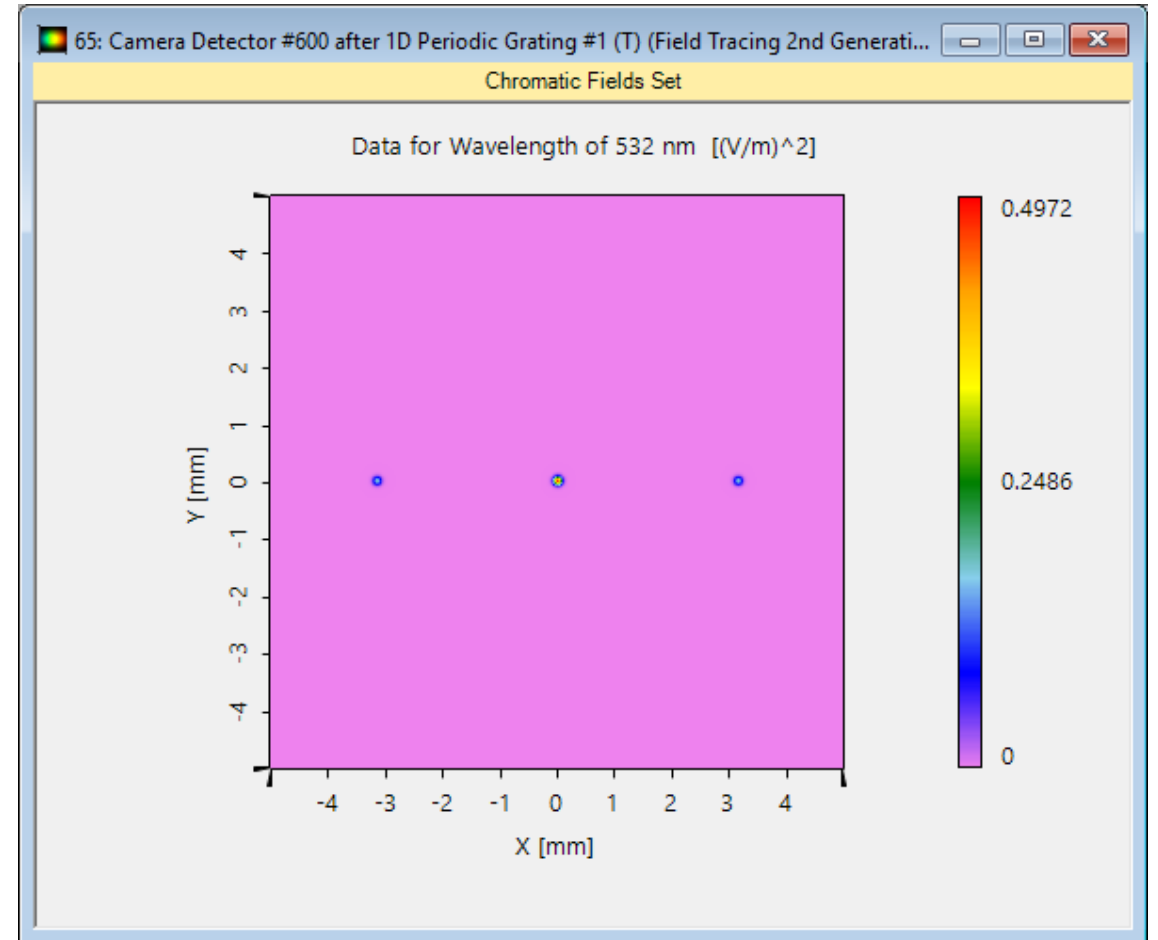

2D – Periodic Grating Structures

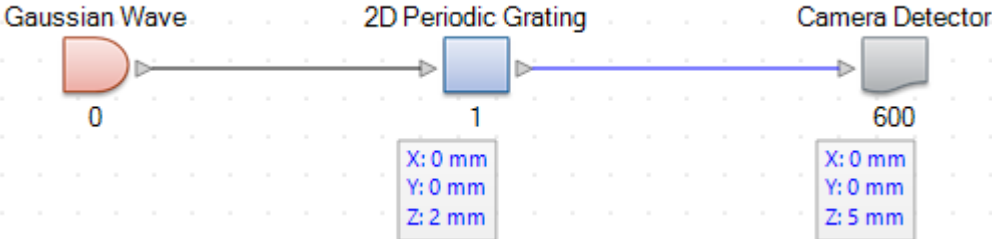

ray tracing:

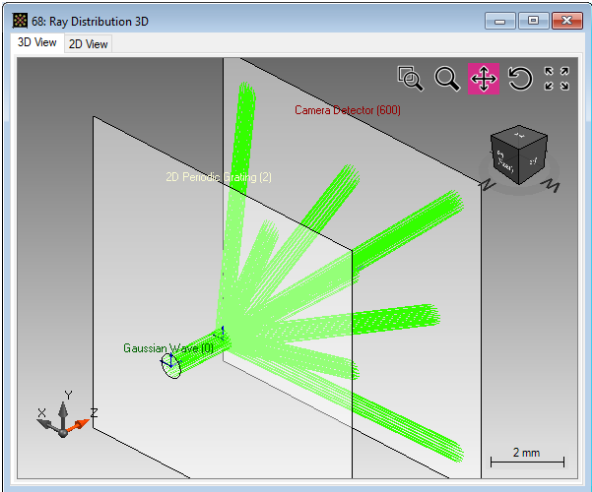

field tracing:

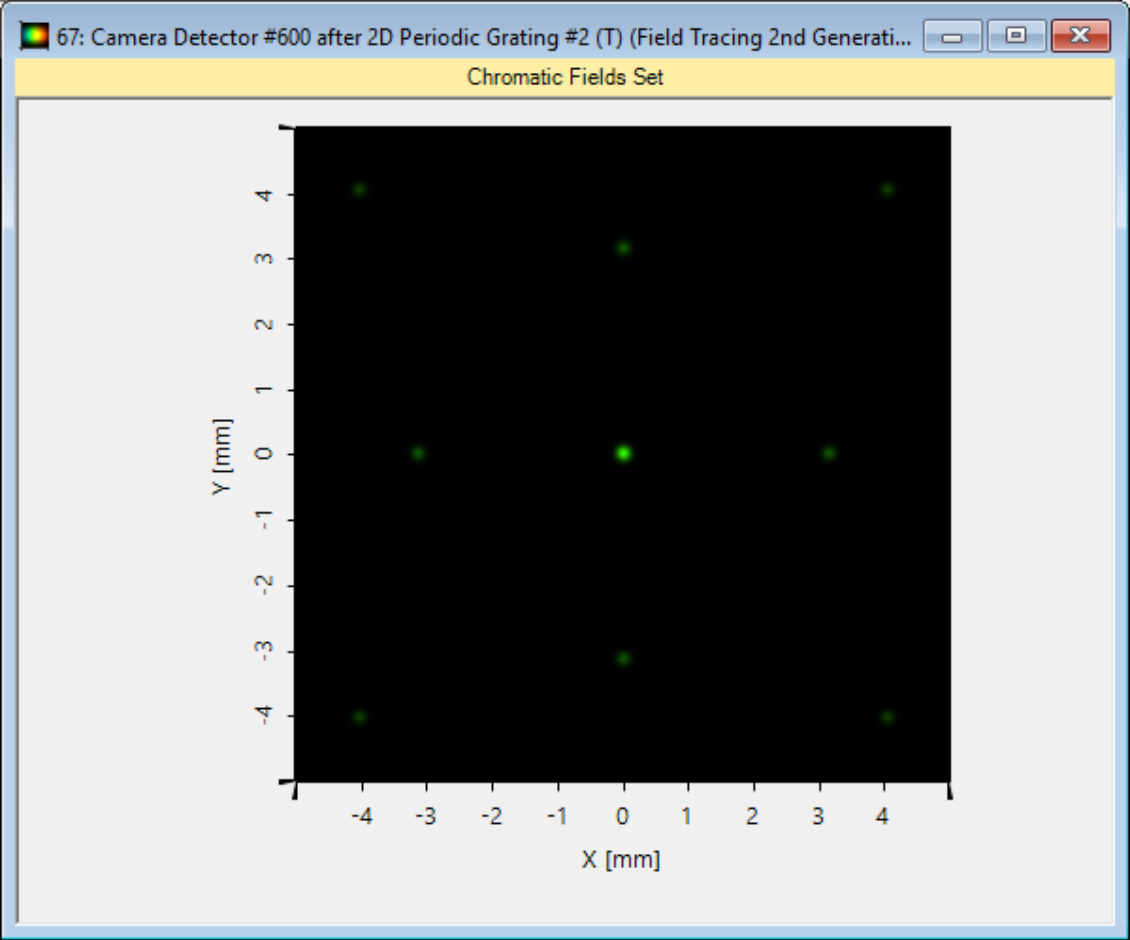

2D – Periodic Grating Structures

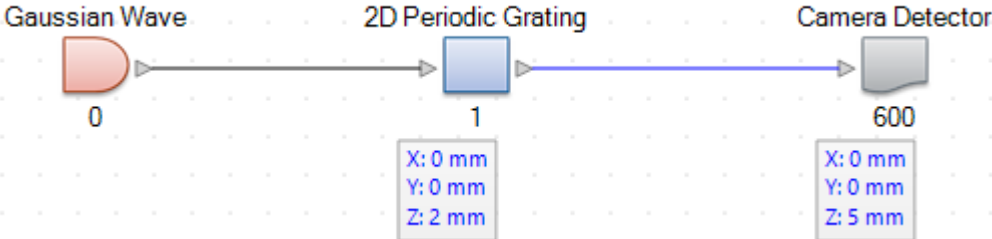

ray tracing:

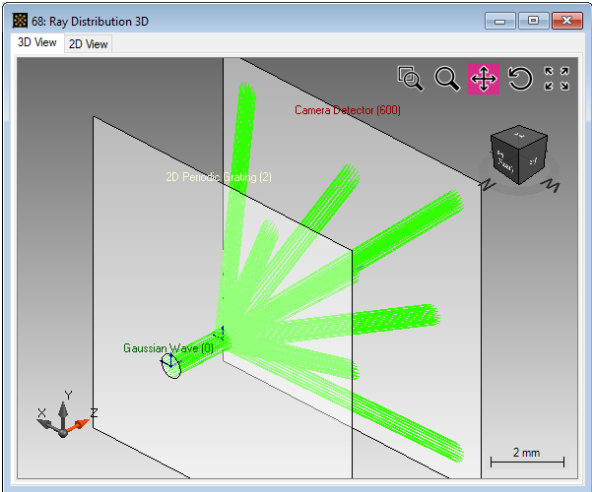

field tracing:

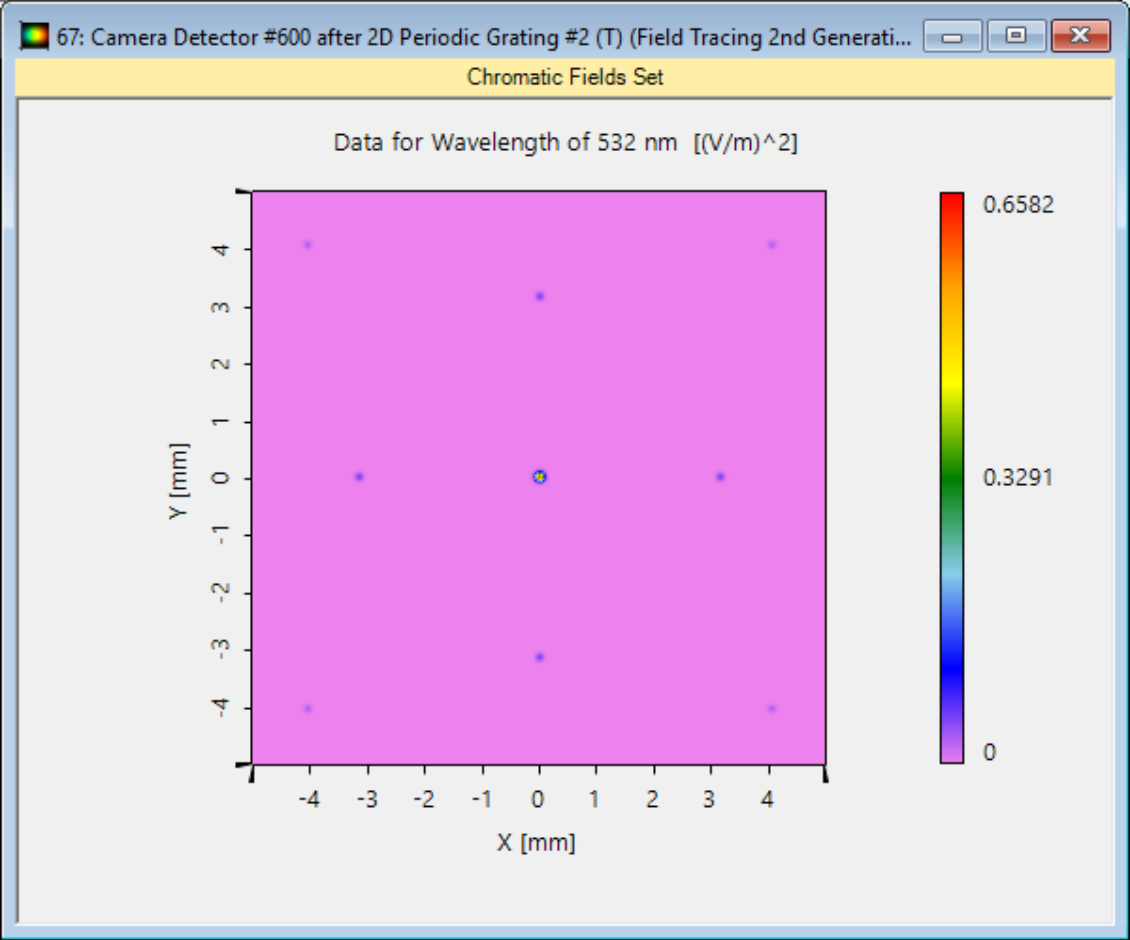

Summary

- VirtualLab Fusion is capable of simulating light propagation of any kind of light source through a periodic microstructure.
 - The grating structures can be either 1D periodic or 2D-periodic (also 3D is possible by using layer decomposition).
 - The microstructures are analyzed rigorously in order to calculate accurate diffraction efficiencies for structure sizes in the range of the used wavelength. For larger structures, thin element approximation can be applied in order to reduce the numerical effort.
 - The gratings can be used in complex optical systems, means in combination with other optical components like e.g. lenses.
-

Document Information

title	Gratings in Complex Optical Systems
document code	Demo.0004
version	1.0
VL version used for simulations	VirtualLab Fusion Summer Release 2019 (7.6.1.18)
category	Demo
further reading	- <u>Configuration of Grating Structures by Using Interfaces</u>
